



**Ohaus Corporation**  
19A Chapin Road  
P.O. Box 2033  
Pine Brook, NJ 07058-2033 USA  
www.ohaus.com

# INSTRUCTION MANUAL

## *Trooper Scale*





**Ohaus Corporation, 19A Chapin Road, P.O. Box 2033, Pine Brook, New Jersey, 07058-2033, USA**

**Declaration of Conformity** We, Ohaus Corporation, declare under our sole responsibility that the instrument models listed below marked with "CE" - are in conformity with the directives and standards mentioned.

**Konformitätserklärung** Wir, die Ohaus Corporation, erklären in alleiniger Verantwortung, dass die untenstehenden Waagentypen, instrument mit "CE" - mit den genannten Richtlinien und Normen übereinstimmen.

**Déclaration de conformité** Nous, Ohaus Corporation, déclarons sous notre seule responsabilité, que les types de instrument ci-dessous cité - munis de la mention «CE» - sont conformes aux directives et aux normes mentionnées ci-après.

**Declaración de Conformidad** Nosotros, Ohaus Corporation, declaramos bajo responsabilidad exclusiva que los modelos de instrumento indicados a continuación - con el distintivo ,CE' - están conformes con las directivas y normas citadas.

**Dichiarazione di conformità** Noi, Ohaus Corporation, U.S.A, dichiariamo sotto nostra unica responsabilità, che i tipi di strumento specificati di seguito - contrassegnati con la marcatura "CE" - sono conformi alle direttive e norme citate.

Instrument Type/Waagentyp/Type de instrument/Modelo de instrumento/Tipo di strumento **Trooper Scale**

Marked with: Gekennzeichnet mit: Munis de la mention: Con el distintivo: Contrassegnati con la	Directive Richtlinie Directive Directiva Direttiva	Standard Norm Norme Norma Norma
	EU 73/23 Low Voltage EU 73/23 Niederspannung EU 73/23 Basse tension EU 73/23 Baja tensión EU 73/23 Bassa tensione  EU 89/336, 92/31, 93/68 Electromagnetic compatibility EU 89/336, 92/31, 93/68 Elektromagnetische Verträglichkeit EU 89/336, 92/31, 93/68 Compatibilité électromagnétique EU 89/336, 92/31, 93/68 Compatibilidad electromagnética EU 89/336, 92/31, 93/68 Compatibilità elettromagnetica	IEC1010-1 & EN60950:1992 Safety Regulations IEC1010-1 & EN60950:1992 Sicherheitsbestimmungen IEC1010-1 & EN60950:1992 Consignes de sécurité IEC1010-1 & EN60950:1992 Disposiciones sobre seguridad IEC1010-1 & EN60950:1992 Prescrizioni . di sicurezza  EN55022:1987 Emissions EN50082-1:1992 Immunity NOTE: The displayed value may be adversely affected under extreme electromagnetic influences, eg. when using a radio unit in the immediate vicinity of the device. Once the interference has been rectified, the product can once again be used for its intended purpose. EN55022:1987 Funkstörungen EN50082-1:1992 Immunität Hinweis: Unter extremen elektromagnetischen Einflüssen z.B. bei Betreiben eines Funkgerätes in unmittelbarer Nähe des Gerätes kann eine Beeinflussung des Anzeigewertes verursacht werden. Nach Ende des Störeinflusses ist das Produkt wieder bestimmungsgemäss benutzbar. EN55022:Emissions parasites EN50082-1:1992 Immunité Remarque: Dans des conditions d'influences électromagnétiques extrêmes, par exemple en cas d'exploitation d'un appareil radio à proximité immédiate de l'appareil la valeur d'affichage risque d'être influencée. Une fois que l'influence parasite est terminée, le produit peut être de nouveau utilisé de manière conforme aux prescriptions. EN55022:1987 Radiointerferencias EN50082-1:1992 Inmunidad Nota: Bajo influencias electromagnéticas extremas, p.ej. cuando funciona una radio en las inmediaciones del aparato, se pueden alterar los valores del display. Cuando concluye el efecto perturbador, el producto puede ser utilizado de nuevo, de acuerdo con lo estipulado. EN55022:1987 Radiointerferenze EN50082-1:1992 Immunità Nota: Il valore visualizzato può essere influenzato negativamente dalla presenza di forti interferenze elettromagnetiche, per esempio quando viene usata una radio in prossimità della bilancia. Eliminata la fonte dell'interferenza, il prodotto può essere nuovamente utilizzato per le funzioni cui è preposto.

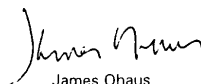
  
 James Ohaus  
 President

**NOTE:** THIS EQUIPMENT HAS BEEN TESTED AND FOUND TO COMPLY WITH THE LIMITS FOR A CLASS A DIGITAL DEVICE, PURSUANT TO PART 15 OF THE FCC RULES.

THESE LIMITS ARE DESIGNED TO PROVIDE REASONABLE PROTECTION AGAINST HARMFUL INTERFERENCE WHEN THE EQUIPMENT IS OPERATED IN A COMMERCIAL ENVIRONMENT. THIS EQUIPMENT GENERATES, USES, AND CAN RADIATE RADIO FREQUENCY ENERGY AND, IF NOT INSTALLED AND USED IN ACCORDANCE WITH THE INSTRUCTION MANUAL, MAY CAUSE HARMFUL INTERFERENCE TO RADIO COMMUNICATIONS. OPERATION OF THIS EQUIPMENT IN A RESIDENTIAL AREA IS LIKELY TO CAUSE HARMFUL INTERFERENCE IN WHICH CASE THE USER WILL BE REQUIRED TO CORRECT THE INTERFERENCE AT HIS OWN EXPENSE.

THIS DIGITAL APPARATUS DOES NOT EXCEED THE CLASS A LIMITS FOR RADIO NOISE EMISSIONS FROM DIGITAL APPARATUS AS SET OUT IN THE INTERFERENCE-CAUSING EQUIPMENT STANDARD ENTITLED "DIGITAL APPARATUS", ICES-003 OF THE DEPARTMENT OF COMMUNICATIONS.

CET APPAREIL NUMERIQUE RESPECTE LES LIMITES DE BRUITS RADIOELECTRIQUES APPLICABLES AUX APPAREILS NUMERIQUES DE CLASSE A PRESCRITES DANS LA NORME SUR LE MATERIEL BROUILLEUR: "APPAREILS NUMERIQUES", NMB-003 EDICTEE PAR LE MINISTRE DES COMMUNICATIONS.

**Unauthorized changes or modifications to this equipment are not permitted.**



**Before plugging in the Scale, make sure that the voltage of the power adapter and plug match.**

# TABLE OF CONTENTS

<b>OVERVIEW OF CONTROLS AND DISPLAY FUNCTIONS .....</b>	<b>1</b>
<b>1. GETTING TO KNOW YOUR TROOPER SCALE .....</b>	<b>2</b>
1.1 Introduction .....	2
1.1.1 Features .....	2
<b>2. INSTALLATION .....</b>	<b>3</b>
2.1 Unpacking and Checking .....	3
2.2 Selecting the Location .....	3
2.3 Connecting Power .....	3
2.3.1 Battery Installation .....	3
2.3.2 AC Power .....	3
2.3.3 Leveling the Scale .....	4
2.3.4 Stabilization .....	4
<b>3. OPERATION .....</b>	<b>4</b>
3.1 Turning On Scale .....	5
3.2 Turning Off Scale .....	5
3.3 Zero Operation .....	5
3.4 Tare Operation .....	5
3.5 Gross/Net/Tare Recall Operation .....	5
3.6 Unit Switch Operation .....	6
3.7 RS232 Commands .....	7
3.7.1 Output Formats .....	7
3.8 Printing Data .....	7
3.8.1 RS-232 Pin Out .....	7
<b>4. SETUP .....</b>	<b>8</b>
4.1 Setup Protection .....	8
4.4.1 Control Functions .....	8
4.4.2 Menu Structure .....	9
4.4.3 Setup Menu .....	10
4.4.4 Readout Menu .....	12
4.4.5 Print Menu .....	16
4.4.6 Lockout Switch Menu .....	18

## TABLE OF CONTENTS (Cont.)

<b>5. CALIBRATION AND SEALING .....</b>	<b>20</b>
5.1 Legal for Trade (LFT) Operation and LFT Sealing .....	25
<b>6. CARE AND MAINTENANCE .....</b>	<b>26</b>
6.1 Troubleshooting .....	26
6.2 Error Codes List .....	28
6.3 Service Information .....	28
6.4 Replacement Parts .....	28
6.5 Accessories .....	28
6.6 Technical Data .....	28

## OVERVIEW OF CONTROLS AND DISPLAY FUNCTIONS

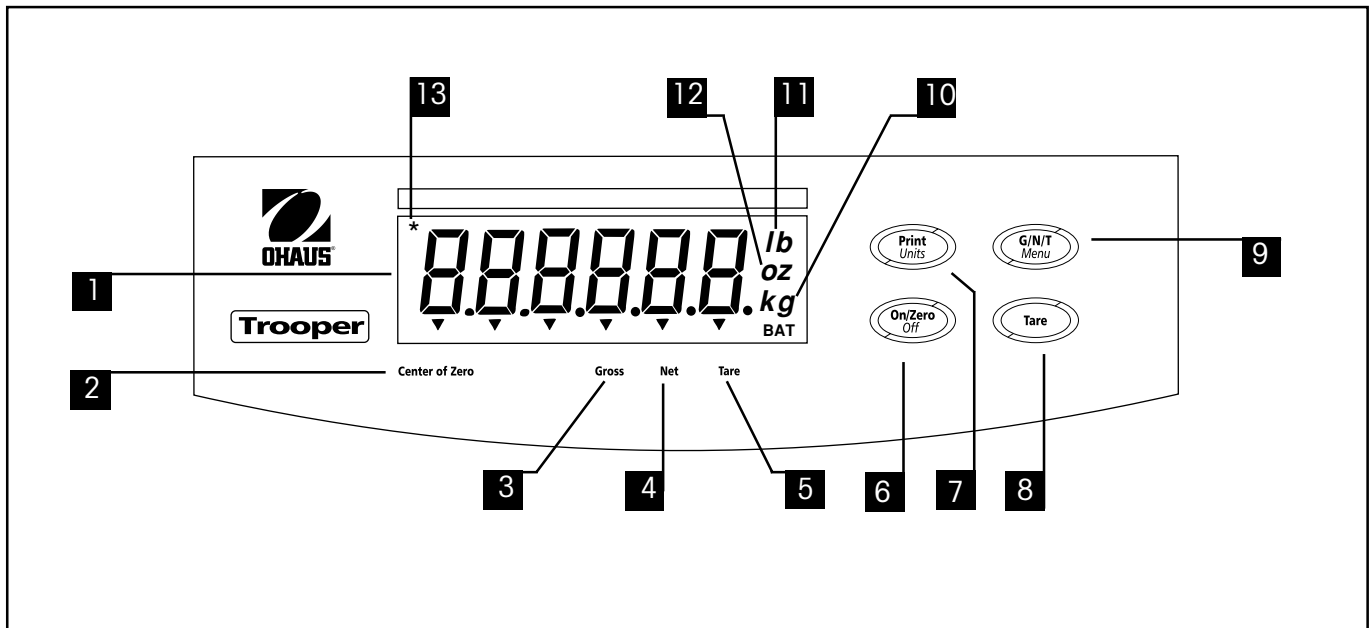

No.	Designation	Function
1	Display	LCD display, indicates weight, modes and setup information.
2	Center of Zero	LCD indicator prompt, indicates center of zero when within +/- 0.25d.
3	Gross	LCD indicator prompt, indicates gross weight.
4	Net	LCD indicator prompt indicates net weight.
5	Tare	LCD indicator prompt indicates tare weight.
6	ON/ZERO/OFF button	Turns Scale on or off. Secondary use, provides zero function.
7	Print/Units button	Short press, prints data which is displayed on the Scale. Long press, changes unit of measure. Longer press, enters counting mode. When in menus, each press advances horizontally through the menus. Finalizes a menu selection.
8	Tare button	When pressed, enters tare value into memory.
9	G/N/T/Menu button	Recalls Gross/Net/Tare. Long press allows entry into menus. When in menus, advances through individual menu items.
10	kg g	LCD indicator, when lit, indicates weight in kilograms. LCD indicator, when lit, indicates weight in grams.
11	lb	LCD indicator, when lit, indicates weight in pounds.
12	oz	LCD indicator, when lit, indicates weight in ounces.

## 1. GETTING TO KNOW YOUR TROOPER SCALE

### 1.1 Introduction

Thank you for deciding to purchase a Trooper Scale from Ohaus. The Ohaus Trooper Scale is a rugged, reliable, electronic scale designed for easy operation.

The Trooper Scale operates from AC power and can also be powered by six Alkaline "C" batteries internally. A six digit LCD display is 1.0 inches/2.5 centimeters in height provides easy visibility when working at distances from the Scale. Four buttons mounted on the front panel enable simple set up procedures. A menu lockout switch can be set to lock out various functions of the Scale to prevent settings from being changed. An RS232 Interface is built in.

Behind your instrument stands OHAUS, a leading manufacturer of precision Indicators, Scales and Balances. An After-market Department with trained instrument technicians is dedicated to providing you with the fastest service possible in the event your instrument requires servicing. OHAUS also has a Customer Service Department to answer any inquiries regarding applications and accessories.

To ensure you make full use of the possibilities offered by your Trooper Scale, please read the manual completely before installation and operation.

#### 1.1.1 Features

Major features include:

- 6 digits, 7-segments, 25 mm Numeric LCD display
- Durable ABS housing
- 4 membrane switches
- Push-button Tare/Clear
- Flexible unit switching-lb/kg/oz/g
- Enhanced digital filtering
- Overload/Underzero display indication
- RS232 Serial Communication in Ohaus RS-Interface
- Up to 100 hours continuous battery operation
- AC & DC power supply
- Low - BAT warning comes on 20 minutes prior to low power point
- Auto shut off for power saving

## **2. INSTALLATION**

### **2.1 Unpacking and Checking**

Open the package and remove the instrument and the accessories. Check the completeness of the delivery. The following accessories are part of the standard equipment of your new Scale.

Remove packing material from the instrument.

Check the instrument for transport damage. Immediately inform your Ohaus dealer if you have complaints or parts are missing. Your Trooper Scale package should contain:

- Trooper Scale
- Warranty card
- AC power adapter
- Instruction Manual
- Lead seal for weights and measures sealing

Store all parts of the packaging. This packaging guarantees the best possible protection for the transport of your instrument.

### **2.2 Selecting the Location**

The Scale should be used in an environment which is free from corrosives, vibration or temperature extremes. These factors will affect displayed weight readings. The Scale should be located on a stable level surface and kept away from vibrating sources such as large machinery. Maximum accuracy will be achieved when the area is clean and vibration free.

### **2.3 Connecting Power**

#### **2.3.1 Battery Installation**

Remove battery cover and insert 6 Alkaline C-type batteries into the battery holder making sure that the batteries are properly orientated (correct polarity).

**NOTE:** It is recommended that when the Trooper Scale is operated from batteries, the Auto-Off Timer feature be turned on to extend battery life. When setting up the Scale, refer to Initial Setup, Readout menu, paragraph 4.4.4.

#### **2.3.2 AC Power**

Connect the AC power cord from the Scale and plug into a convenient power outlet.



**NOTICE:**  
**The socket/outlet must be installed near  
the equipment and shall be easily accessible.**

## 2. INSTALLATION (Cont.)

### 2.3.3 Leveling the Scale

Exact horizontal positioning and stable installation are prerequisites for repeatable results. To compensate small irregularities or inclinations at the location, the instrument can be leveled.

For exact horizontal positioning, the Scale is equipped with a level indicator located at the rear.

Adjust the leveling feet until the air bubble in the indicator is centered.

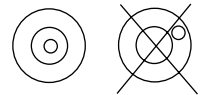

**NOTE:** The instrument should be leveled each time its location is changed.

### 2.3.4 Stabilization

Before initially using the Scale, allow time for it to adjust to its new environment. Recommended warm up period is five (5) minutes.

## 3. OPERATION

The Trooper Scale has been factory calibrated and is ready for operation. You can operate the scale at this point using the factory default settings. You can check the default menu settings on page 9. All bolded items on the menu are the factory default settings. The scale will operate in the default mode. If you want to change the settings, continue with Section 4, Setup.

When the Scale is positioned for operation, follow the operational procedure outlined next.

### 3. OPERATION (Cont.)



#### 3.1 Turning On Scale

Press and hold **ON/ZERO/OFF** button until the LCD display appears, then release **ON/ZERO/OFF** button. The display momentarily displays segment check, the software revision of the Scale and then goes into a weighing mode.

#### 3.2 Turning Off Scale

To turn the Scale off, press the **ON/ZERO/OFF** button until OFF is displayed.

#### 3.3 Zero Operation

Using a *short* duration press, press **ON/ZERO/OFF** button to zero the Scale. The display acknowledges by indicating the selected measuring unit followed by a zeroed display.

**NOTE:** Stable cursor must be lit to accept zero operation.

Place item to be weighed on the scale platform. The display indicates a sample of 5kg, gross weight.

#### 3.4 Tare Operation

When weighing material or objects that must be held in a container, taring stores the container weight in the Indicator's memory. To store the container weight, proceed as follows:

Place the container on the scale. Sample shown is 2kg.

Press **TARE** button. Scale is tared and shows Net weight.

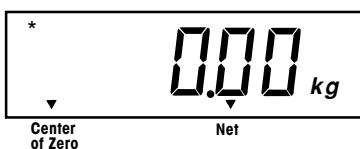

### 3. OPERATION (Cont.)



#### 3.5 Gross/Net/Tare Recall Operation

When a container has been placed on the platform and tared, its weight is stored in memory. Adding material to the container is shown as NET weight. The gross weight is a combination of the tared weight and the material. The **G/N/T/MENU** button allows switching between GROSS, NET and TARE weights.

Repeatedly press (short presses) the **G/N/T/MENU** button to cycle through Gross, Tare and Net readings. The sample illustrations indicate a tare weight of 2kg simulating a container, a net weight of 8kg which would be the material in a container and a gross weight of 10kg which is the total weight of the container and material. After 3 seconds, display returns to Net weight.

#### 3.6 Unit Switch Operation

To switch measuring units, proceed as follows:

Press and hold **PRINT/UNITS** button until display changes to selected measuring unit. Depending on which units are enabled in the menu, you have a choice of g, lb, kg or oz. The display sample indicates 8kg load changed to lbs shown as a net weight because a tared weight of 2kg was used and stored in memory.

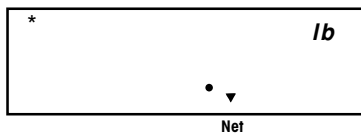

### 3. OPERATION (Cont.)

#### 3.7 RS232 Commands

All communication is accomplished using standard ASCII format. Characters shown in the following table are acknowledged by the Scale. Invalid command response "ES" error indicates the Scale has not recognized the command. Commands sent to the Scale must be terminated with a carriage return (CR) or carriage return-line feed (CRLF). Data output by the Scale is always terminated with a carriage return-line feed (CRLF).

##### 3.7.1 Output Formats

Data output can be initiated in one of two ways; 1) By pressing **PRINT/UNITS** button, 2) Sending a print command ("P") from a computer or a PLC.

The output format is illustrated in the RS232 command table which follows.

**RS232 COMMAND TABLE**

Command Character	Description
<b>?</b>	Print current mode: kg, g, lb., oz.
<b>P</b>	Same as pressing PRINT button..
<b>T</b>	Same as pressing TARE button.
<b>Z</b>	same as pressing ZERO button.
<b>xS</b>	Print Stable only. Where x=0 Off, and x=1 On
<b>AS</b>	Automatically send data when stable after motion.
<b>xxxxS</b>	Send at interval. Where xxxx=1 to 3600 seconds.
<b>CS</b>	Send as fast as possible (continuous print)
<b>M</b>	Increment to next enabled unit

To turn auto printing, interval printing or continuous printing off, send P to reset normal printing mode.

#### 3.8 Printing Data

Printing data to an external computer or printer requires that the communications parameters in the Print menu, be set first. Refer to paragraph 4.4.5 Print Menu for proper set up.

To print data, press **PRINT/UNITS** button with a short press. The display acknowledges by momentarily blinking off.

**NOTE:** If you hold this button down too long, the display will advance to another measuring unit.

##### 3.8.1 RS-232 Pin Out.

1	N/C
2	Data In (RXD)
3	Data Out (TXD)
4	N/C
5	Ground
6, 7, 8, 9	N/C

### 4. SETUP

For first time setup, step through all menus and set the parameters as desired.

#### 4.1 Setup Protection

The Trooper Scale is equipped with menus which permit certain functions to be locked out (not changed) during operation. If you intend to lock out changes to the setup selections you make, you will need to access the Lock Switch located on the main PC circuit board following the setup procedure.

The Scale has five menus; CAL, SETUP, READ, PRINT and LOCSW which are entered by pressing and holding the **G/N/T/MENU** button until MENU is displayed, then releasing it. The display then switches to SETUP. To access the rest of the menus, the **PRINT/UNITS** button is repeatedly pressed until the desired menu is reached.

#### 4.4.1 Control Functions

During setup, only the **PRINT/UNITS** and **G/N/T/MENU** buttons are used.

##### **PRINT/UNITS** Button

Change between menus horizontally or change sub-menu parameters.

##### **G/N/T/MENU** Button

Press and hold to enter menu. Enters menu and steps through sub-menus vertically.

#### 4.4.2 Menu Structure

The following table illustrates the menu structure in the Trooper Scale.

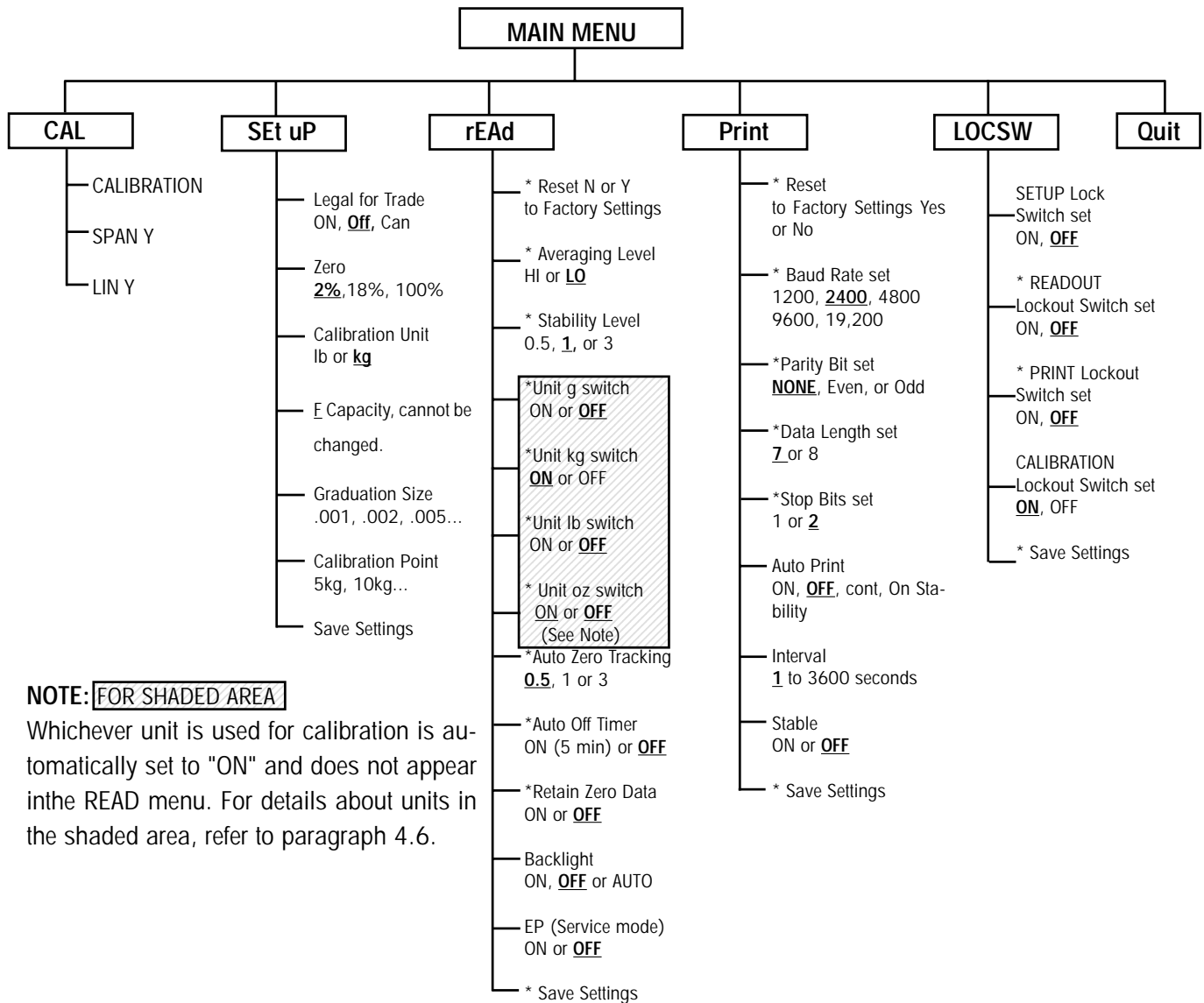

**NOTE:** FOR SHADED AREA

Whichever unit is used for calibration is automatically set to "ON" and does not appear in the READ menu. For details about units in the shaded area, refer to paragraph 4.6.

Press **(G/NIT/MENU)** to enter the display submenu or select a displayed setting.

Press **(PRINT/UNITS)** to change the displayed submenu or setting.

Factory default settings are shown in **underlined and boldface** type.

When CAL switch on the circuit board is in the LFT position, all of the menus can be reached except CALIBRATION Menu, but only the submenus which are marked '\*★' can be setup, see menu structure.

## 4.4.3 Setup Menu

The Setup Menu is used to set up the Scale for the first time.



SET uP.



LFTOFF



0 2

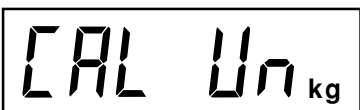

CAL Un kg

### Procedure

With the Scale ON, press and hold the **G/N/T/MENU** button until MENU is displayed. When you release **G/N/T/MENU** button, SETUP is displayed when the CALIBRATION Lock Switch (software) is in the locked position. When the CALIBRATION Lock Switch is locked, the Scale **will not** permit calibration.

Press **PRINT/UNITS** button, SETuP is displayed.

Press **G/N/T/MENU** button, LFTOFF is displayed. Legal for trade selections are:

'LFT ON' - LFT is ON

'LFTOFF' - LFT is OFF

'LFTCAN' - LFT is set for Canada

Press **PRINT/UNITS** button and select either ON, OFF or Canada.

Press **G/N/T/MENU** button, 0 2 is displayed. This is the Zero 2%, 18% or 100% setting. 2% - zero operation range is - 2% to + 2%. 18% - zero operating range is - 2% to +18%, 100% - zero operation range is -2% to +100%.

**NOTE:** If LFT is ON, only 2% and 18% are available.

Press **PRINT/UNITS** button, and select either 2%, 18% or 100%.

Press **G/N/T/MENU** button, CAL Un kg is displayed.

This is the calibration unit setting. Selections are:

'lb' - calibration unit is lb

'kg' - calibration unit is kg.

Press **PRINT/UNITS** button, and select either kg or lb.

**NOTE: The Scale is factory calibrated. After changing the calibration unit, the Scale must be recalibrated before using!**

## 4.4.3 Setup Menu (Cont.)

A rectangular digital display showing the text 'Gd 0.1 kg' in a seven-segment font. 'Gd' is on the left, '0.1' is in the middle, and 'kg' is on the right.

Press **PRINT/UNITS** button until desired capacity value is reached.

Press **G/N/T/MENU** button, Gd 0.1 is displayed. This is the graduation size. For available selections, press **PRINT/UNITS** button until desired graduation value is reached.

A rectangular digital display showing the text 'CP 30 kg' in a seven-segment font. 'CP' is on the left, '30' is in the middle, and 'kg' is on the right.

Press **G/N/T/MENU** button, CP 30 kg is displayed. This is the full scale calibration point setting. Default is approximately 2/3 full scale capacity and can be selected depending upon the model.

Press **PRINT/UNITS** button until desired calibration value is reached.

A rectangular digital display showing the text 'SAVE' in a seven-segment font.

Press **G/N/T/MENU** button to end this block, SAVE is displayed.

Press **G/N/T/MENU** button, rEAD is displayed which is the next menu or press **PRINT/UNITS** button to return to Setup menu.

### 4.4.4 Readout Menu

The Readout menu is used to adapt the Scale to environmental conditions, set measuring units on/off, auto zero tracking, timer on/off, retain zero data and backlighting. Review all of the settings available before proceeding.

A rectangular digital display showing the text 'rEAd .' in a seven-segment font. The 'r' is lowercase, 'E' is uppercase, 'A' is uppercase, and 'd' is lowercase. A period follows the 'd'.

A rectangular digital display showing the text 'rESEt n' in a seven-segment font. The 'r' is lowercase, 'E', 'S', and 'E' are uppercase, 't' is lowercase, and 'n' is lowercase.

A rectangular digital display showing the text 'AL LO' in a seven-segment font. 'AL' and 'LO' are both in uppercase.

#### Procedure

To select any of the items in the Readout menu, proceed as follows: **NOTE:** If you have entered from the preceding menu, disregard the first step.

With the Scale ON, press and hold the **G/N/T/MENU** button until MENU is displayed. When you release the **G/N/T/MENU** button, CAL is displayed, then press **PRINT/UNITS** button, until rEAd is displayed.

Press **G/N/T/MENU** button, rESEt n is displayed. This allows resetting the readout menu to factory defaults. rESEt n = no and does not reset settings. rESEt y = yes and will reset the entire readout menu as follows: AL Lo, StAb 1, Un Off g, Un On kg, Un On l, Un Off oz, AZt 0.5, Aot Off, rZd Off and Backlight Off.

Press **PRINT/UNITS** button, and select N or Y.

#### AVERAGING LEVEL

Averaging level compensates for vibration or excessive air currents on the scale platform. During operation, the Scale continually takes weight readings from the load cell. Successive readings are then digitally processed to achieve a stabilized display. Using this feature, you specify how much processing you need.

HI and LO settings are available.

HI setting:

More processing, greater stability and slower stabilization time.

LO setting:

Less processing, less stability and faster stabilization time.

#### 4.4.4 Readout Menu (Cont.)

##### Procedure

##### AVERAGING LEVEL (Cont.)

Press **G/N/T/MENU** button, AL LO is displayed. This is averaging level settings. Selections are:

'Lo' - Averaging level is low

'Hi' - Averaging level is high.

Press **PRINT/UNITS** button, and select LO or HI.



##### STABILITY

The stability range specifies the weighing results and must be within a preset tolerance limit for a certain time to turn the stability indicator ON. When a displayed weight changes beyond the allowable range, the stability indicator turns OFF, indicating an unstable condition. Factory default setting is shown in bold type.

.5d Smallest range: stability indicator is ON only when displayed weight is within .5 divisions.

**1d Normal setting. - Fixed for LFT**

3d More stable course

Press **G/N/T/MENU** button, StAb1 is displayed. The stability range specifies the weighing results and must be within a preset tolerance limit for a certain time to turn the stability indicator ON. When a displayed weight changes beyond the allowable range, the stability indicator turns OFF, indicating an unstable condition. 0.5 d smallest range, stability indicator is ON only when displayed weight is stable within 0.5 divisions. 1 d-stable within 1 division. 3 d-largest range, stability indicator is ON even though displayed weight changes 3 divisions. Factory default setting is 1.

Press **PRINT/UNITS** button, and select 0.5, **1**, or 3. Normal 1d stability is default/recommended.

## 4.4.4 Readout Menu (Cont.)

A rectangular digital display showing the text 'Un OFF g' in a seven-segment font. 'Un' is on the left, 'OFF' is in the middle, and 'g' is on the right.

A rectangular digital display showing the text 'Un ON lb' in a seven-segment font. 'Un' is on the left, 'ON' is in the middle, and 'lb' is on the right.

A rectangular digital display showing the text 'Un ON kg' in a seven-segment font. 'Un' is on the left, 'ON' is in the middle, and 'kg' is on the right.

A rectangular digital display showing the text 'Un ON oz' in a seven-segment font. 'Un' is on the left, 'ON' is in the middle, and 'oz' is on the right.

A rectangular digital display showing the text 'AZt 0.5' in a seven-segment font. 'AZt' is on the left and '0.5' is on the right.

**Procedure****UNITS SELECTION**

Press **G/N/T/MENU** button, Un OFF g is displayed.

Press **PRINT/UNITS** button, and select ON or OFF. OFF is the default setting.

Press **G/N/T/MENU** button, Un ON lb is displayed. This is unit pounds which can be turned ON or OFF. This will be displayed when CAL UNIT kg was selected. When lb was selected as calibration unit, kg will display.

Press **PRINT/UNITS** button, and select ON or OFF. ON is the default setting.

Press **G/N/T/MENU** button, Un OFF oz is displayed. This unit is ounces which can be turned ON or OFF. Default setting is OFF.

Press **PRINT/UNITS** button, and select ON or OFF.

**NOTE:** If CAL Unit is kg, then UNIT kg is fixed to ON menu not shown. The same if CAL Unit is set to lb.

**AUTO ZERO**

Press **G/N/T/MENU** button, AZt 0.5 is displayed. This is the Auto Zero Threshold setting. Auto Zero minimizes the effects of temperature changes and small disturbances on the zero reading. The Scale maintains the zero display until the threshold is exceeded. Settings are shown as follows:

OFF

0.5d Sets threshold to 0.5 divisions. - Fixed in LFT

1d Sets threshold to 1 division.

3d Sets threshold to 3 divisions.

Factory default setting is 0.5d.

Press **PRINT/UNITS** button, and select either 0.5, 1 or 3.

## 4.4.4 Readout Menu (Cont.)

**AUTO POWER OFF**

Press **G/N/T/MENU** button, AOfOFF is displayed. This is the Auto Off Timer. When set ON, the Scale will shut off automatically after 5 minutes has elapsed based on the condition that no button is pressed and the scale platform is stable during that period.

Press **G/N/T/MENU** button, and select ON or OFF. OFF is the default setting.

**RETAIN ZERO DATA**

Press **G/N/T/MENU** button, Un rZdOFF is displayed. This is Retain Zero Data which can be turned on or off.

When set On, the Scale stores the current zero point and restores it on the power-up.

Press **PRINT/UNITS** button, and select ON or OFF. OFF is the default setting.

**LCD BACK LIGHT**

Press **G/N/T/MENU** button, bLAUTO is displayed. You can select to have the LCD backlight either on continuously, off or in an automatic mode which turns off the display in 5 seconds.

Press **PRINT/UNITS** button, and either select ON, OFF or Auto. Auto is the default setting.

**EP**

This is service function and is not a user operated command. OFF is the default setting.

**SAVE**

Press **G/N/T/MENU** button to end this block, SAVE is displayed. All settings are retained.

Press **G/N/T/MENU** button, setting are saved and PRINT is displayed which is the next menu or press **PRINT/UNITS** button to go back to Setup menu without saving.

**NOTE:** (If initial setup, go to the next paragraph. To exit from the Setup, press **PRINT/UNITS** button to skip to PRINT then to LOCKSW, then QUIT. Press **G/N/T/MENU** button to go back to the weighing mode).

## 4.4.5 Print Menu

The Print menu provides data communication settings which can be entered. It contains 9 submenus: Reset, Baud rate, Parity Bit, Data Length, Stop Bits, Auto Print, Interval, Stable and Save.

A rectangular digital display showing the text "Pr int ." in a monospaced font.

### Procedure

#### PRINT

To select any of the items in the Print menu, proceed as follows: **NOTE:** If you have entered from the preceding menu, disregard the first step.

With the Scale ON, press and hold the **G/N/T/MENU** button until MENU is displayed. When you release the **G/N/T/MENU** button, CAL is displayed, then press **PRINT/UNITS** button, until Print is displayed.

#### RESET

Press **G/N/T/MENU** button, rESEtn is displayed. This allows resetting the Print menu to factory defaults.

rESEtn = no does not reset settings. rESEty = yes will reset the entire Print menu as follows:

Baud rate =2400, parity =none, data length=7, stop bit=2.

Press **PRINT/UNITS** button, and select N or Y.

#### BAUD RATE

Press **G/N/T/MENU** button, bd2400 displayed.

Press **PRINT/UNITS** button, and select desired baud rate. Baud rate selections are: 1200, 2400, 4800 9600 and 19200. 2400 is the default setting.

#### PARITY

Press **G/N/T/MENU** button, PAR NO is displayed. This is the parity bit.

Press **PRINT/UNITS** button, and select desired parity of NO=none, Odd=odd, E=even. Default setting is none.

A rectangular digital display showing the text "rESEtn" in a monospaced font.

A rectangular digital display showing the text "bd2400" in a monospaced font.

A rectangular digital display showing the text "PAR NO" in a monospaced font.

## 4.4.5 Print Menu

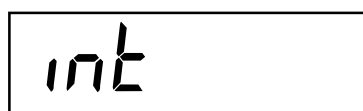

**Procedure (Cont.)****DATA**

Press **G/N/T/MENU** button, dAtA 7 is displayed. This is the data length.

Press **PRINT/UNITS** button, and select desired data length of 7 or 8. Default setting is 7.

**STOP BITS**

Press **G/N/T/MENU** button, StOP 2 is displayed. This is the stop bit.

Press **PRINT/UNITS** button, and select desired stop bit of 1 or 2. Default setting is 2.

**AUTO PRINT**

Auto print has settings which enables data to a printer or PC to be set Off, run continuously, at selected preset intervals or on stability. On stability will print first stable non-zero value after each change in weighing value.

Press **G/N/T/MENU** button, AP OFF is displayed.

Press **PRINT/UNITS** button, and select either Off, Continuous, Interval or On Stability. Default setting is OFF.

**INTERVAL - PRINTING**

When interval has been selected in the previous step, you may now set an interval from 1 to 3600 seconds. If Interval was not selected, ignore these steps.

Press **G/N/T/MENU** button, int is displayed, after a few seconds, a second display appears which allows you to set in the time in seconds.

Pressing the **PRINT/UNITS** button advances the zero from left to right. Sample at left indicates 10 seconds.

**NOTE:** 0000 not valid.

### 4.4.5 Print Menu



A digital display showing the text "Stb OFF" in a seven-segment font. The characters are arranged in a single line within a rectangular border.



A digital display showing the text "SAVE" in a seven-segment font. The characters are arranged in a single line within a rectangular border.

#### INTERVAL - PRINTING (Cont.)

Pressing the **TARE** button increments the digit from 1 to 0. When the desired number of seconds have been entered, press the **G/N/T/MENU** button. Stb OFF is displayed.

#### STABLE

When set ON, allows only stable weight values to be printed. When set OFF, prints immediate value with an indication of stability. In LFT, fixed to ON.

With Stb OFF displayed, press **PRINT/UNITS** button, and select ON or OFF. Default setting is OFF.

#### SAVE

Press **G/N/T/MENU** button to end this block, SAVE is displayed. All settings are retained.

Press **G/N/T/MENU** button to save settings, LOCSW is displayed which is the next menu or press **PRINT/UNITS** button to go back to Read menu without saving.

**NOTE:** (If initial setup, go to the next paragraph. To exit from the Setup, press **PRINT/UNITS** button to skip to LOCKSW, then QUIT. Press **G/N/T/MENU** button to go back to the weighing mode).

### 4.4.6 Lockout Switch Menu

Lockout Switch menu (LOCSW) is a software controlled option which can lock the settings in the Calibration, Setup, Readout, and Print menus to prevent tampering. When used in conjunction with the Lock Switch on the printed circuit board, the Calibration, Setup, Readout and Print menus can be read only and not changed by an operator or the switch can be left in place and the LOCSW menu is used to prevent accidental changes..

#### Procedure

To select any of the items in the Lockswitch menu, proceed as follows: **NOTE:** If you have entered from the preceding menu, disregard the first step.

## 4.4.6 Lockout Switch Menu (Cont.)







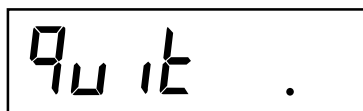

**Procedure (Cont.)**

With the Scale ON, press and hold the **G/N/T/MENU** button until MENU is displayed. When you release the **G/N/T/MENU** button, CAL is displayed, then press **PRINT/UNITS** button, until LOCSW is displayed.

Press **G/N/T/MENU** button, LSTOFF is displayed. This permits locking the Setup menu. OFF is unlocked, ON is read only (locked). This menu is hidden if the CAL jumper is off.

Press **PRINT/UNITS** button, and select ON or OFF.

Press **G/N/T/MENU** button, LrdOFF displayed. This permits locking the Readout menu. OFF is unlocked, ON is read only (locked).

Press **PRINT/UNITS** button, and select ON or OFF.

Press **G/N/T/MENU** button, LPtOFF is displayed. This permits locking the Print menu. OFF is unlocked, ON is read only (locked).

Press **PRINT/UNITS** button, and select ON or OFF.

Press **G/N/T/MENU** button, LCLON is displayed. This permits locking the Calibration menu. OFF is un locked, ON is read only (locked). This menu is hidden if the LFT switch is in the LFT position.

Press **PRINT/UNITS** button, and select ON or OFF.

Press **G/N/T/MENU** button to end this block, SAVE is displayed.

Press **G/N/T/MENU**, Quit is displayed.

Press **PRINT/UNITS** button to go to CAL or press **G/N/T/MENU** button, Scale returns to a weighing mode.

**NOTE:** At this point, the Lock Switch must be set in order to lock out the menus.

## 5. CALIBRATION AND SEALING

Span calibration ensures that the Scale reads correctly within specifications. For best results, calibrate at full capacity. Calibration unit can be set to either kg or lb.

**NOTE: When the Scale is used in Legal for trade applications, the calibration menu is locked out and is not accessible.** This is to prevent unauthorized personnel from changing calibration.

### IMPORTANT:

**Before beginning calibration, make sure masses are available. If you begin calibration and realize calibration masses are not available, exit the menu.** The Scale will retain previously stored calibration data. Calibration should be performed as necessary to ensure accurate weighing. You have a choice of either span or linearity calibration. Span calibration checks zero and full span calibration points. Linearity calibration checks zero, mid span and full span points.

Before calibrating the scale, first determine if a recalibration is really needed. Place the available calibration masses onto the platform. As each mass is added, the scale display should show the correct weight to within +/- 1 scale division. If the scale is within the tolerance, there is no need to recalibrate the scale.

If it is determined that the scale must be recalibrated **do not continue until you are certain that you have suitable calibration masses.**

If calibration masses are available you must select the correct calibration units (pound masses or kilogram masses) before calibrating the scale. The desired unit can be chosen in the setup menu on page 10.

After the desired calibration unit has been chosen, advance to the LOCSW menu to turn the calibration lock switch off. This software lock is in place to prevent accidental calibration.

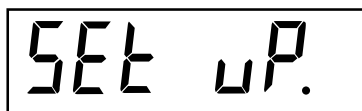

### Procedure

#### TURNING CALIBRATION LOCK SWITCH OFF

To turn the software lock off:

Press and hold the **G/NT/MENU** button until MENU appears. Release it and SETuP appears. (if already in the main menu, skip to the next step).

Repeatedly press the **PRINT/UNITS** button until LOCSW is displayed.

Repeatedly press the **G/NT/MENU** button until LCL ON is displayed.

Press the **PRINT/UNITS** button to scroll through the choices until LCLOFF appears.

Press the **G/NT/MENU** button repeatedly until the scale returns to weighing

Before calibrating, make sure that you have the correct masses available:

## 5. CALIBRATION AND SEALING (Cont.)

### Procedure (Cont.)

#### TURNING SOFTWARE LOCK OFF

Cal in kg:	Span cal choices	Linearity cal (fixed)
TR3RS	1, <b>2</b> , 3kg	2 & 3 kg
TR6RS	2, <b>4</b> , 6kg	4 & 6 kg
TR15RS	5, <b>10</b> , 15kg	10 & 15 kg
TR30RS	10, <b>20</b> , 30kg	20 & 30 kg
Cal in lb:	Span cal choices	Linearity cal (fixed)
TR3RS	2, <b>4</b> , 6 lb	4 & 6 lb
TR6RS	5, <b>10</b> , 15 lb	10 & 15 lb
TR15RS	10, <b>20</b> , 30 lb	20 & 30 lb
TR30RS	20, <b>40</b> , 60 lb	40 & 60 lb

For span calibration, there are a number of choices for calibration. The highlighted number is the default.

To change the span calibration value read the setup section of the menu on page 10. In the Setup menu, change the CP selection to the desired value.

When the desired selection has been chosen and the masses are available, you are ready to begin the calibration routine.

### Procedure

#### SPAN CALIBRATION

With the Scale ON, press and hold the **G/N/T/MENU** button until MENU is displayed. When you release the **G/N/T/MENU** button, CAL is displayed. If the display shows SETuP, read the section on turning off the Calibration Lock Switch or check the settings for legal for trade.

Press **G/N/T/MENU** button, SPAN Y is displayed.

Press **G/N/T/MENU** button, -C- is displayed. The scale MUST be stable during this period and is establishing a zero point. After a few seconds, the requested weight value is displayed.

CAL .

SPAN 4

-C-

## 5. CALIBRATION AND SEALING (Cont.)

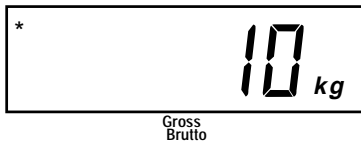
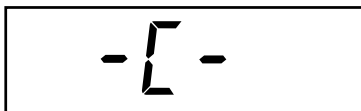

### Procedure (Cont.)

#### SPAN CALIBRATION

Place the indicated mass on the platform. Keep the platform stable during this period. The sample illustration indicates a 15kg scale.

If at this point you are uncertain of the process or if the correct weights are not available, the calibration routine can be aborted by pressing the **PRINT/UNITS** button, or by turning the scale off by pressing and holding the **ON/ZERO/OFF** button.

Press **G/N/T/MENU** button, -C- is displayed while the Scale stores the reading and then displays the weight of the mass.

If the calibration was successful, the calibration mass is displayed and the calibration data is saved automatically. If unsuccessful, refer to the troubleshooting section.

Remove calibration masses from platform.

After the calibration routine is complete, check the scale again to see if the scale has been accurately calibrated. If so return to the lockout menu and restore the calibration software lock to "ON":

**NOTE:** If the Scale is to be used for legal for trade applications, it must be calibrated and the LFT Lock Switch must be set ON to lock out the menus. Refer to paragraph 5.1 for sealing for legal for trade use.

## 5. CALIBRATION AND SEALING (Cont.)

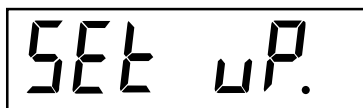

SET uP.

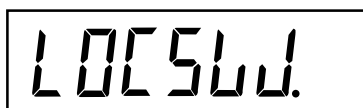

LOCSW.



LCL OFF



LCL ON

### Procedure

#### TURNING CALIBRATION LOCK SWITCH ON

To turn the software lock on:

Press and hold the **G/N/T/MENU** button until MENU appears. Release it and SETuP appears. (if already in the main menu, skip to the next step).

Repeatedly press the **PRINT/UNITS** button until LOCSW is displayed.

Repeatedly press the **G/N/T/MENU** button until LCL OFF is displayed.

Press the **PRINT/UNITS** button to scroll through the choices until LCLON appears.

Press the **G/N/T/MENU** button repeatedly until the scale returns to weighing

The scale is now ready for weighing.

## 5. CALIBRATION AND SEALING (Cont.)

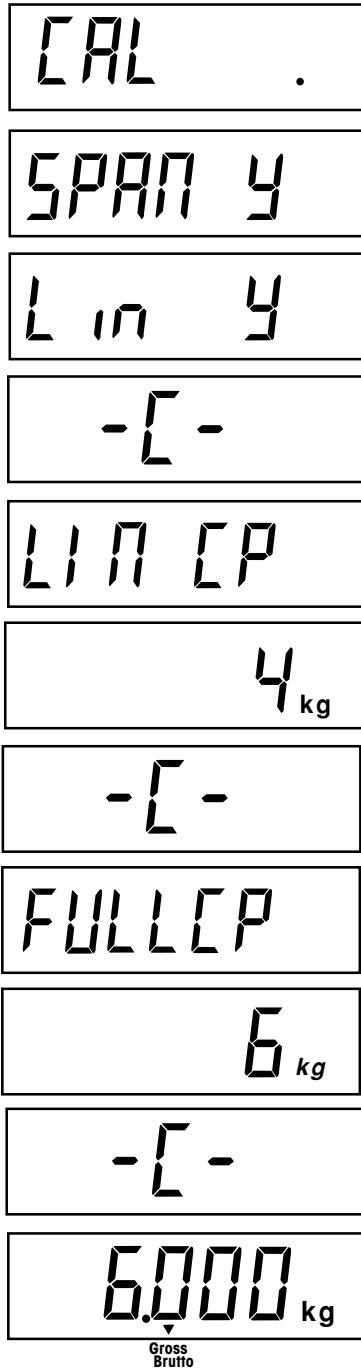
**Procedure****LINEARITY CALIBRATION**

As with span calibration, confirm that calibration is really required. If required, refer to page 20 and turn the Calibration Lock Switch off.

With the Scale ON, press and hold the button

**G/N/T/MENU** until MENU is displayed. When you release the **G/N/T/MENU** button, CAL is displayed.

Press **G/N/T/MENU** button, SPAN Y is displayed.

Press **PRINT/UNITS** button, Lin Y is displayed.

Press **G/N/T/MENU** button, -C- is displayed. The scale MUST be stable during this period and is establishing a zero point. After a few seconds, the display flashes LIN CP twice and the requested weight value is displayed. The sample illustration indicates a 4kg mid point for a 6kg scale. (Linearity calibration for Trooper is 0, 2/3 and full capacity).

Place the indicated mass on the platform. Keep the platform stable during this period.

Press **G/N/T/MENU** button, -C- is displayed. The scale MUST be stable during this period and is establishing a zero point. After a few seconds, the display flashes FULLCP and the requested weight value is displayed.

Place the indicated mass on the platform and press the **G/N/T/MENU** button -C- is displayed.

If linearity calibration was successful, the calibration mass is displayed and the calibration data is saved automatically. If unsuccessful, refer to the troubleshooting section.

Remove calibration masses from platform. After calibration, refer to page 19 and turn the Calibration Lock Switch On.

**NOTE:** If the Scale is to be used for legal for trade applications, it must be calibrated and the Lock Switch must be set to lock out the menus. Refer to paragraph 5.1 for sealing for legal for trade use.

### 5.1 Legal for Trade (LFT) Operation and LFT Sealing

Legal for Trade (LFT) operation is possible through a LFT Lock Switch located on the PC board. The Scale must be calibrated prior to performing this procedure.

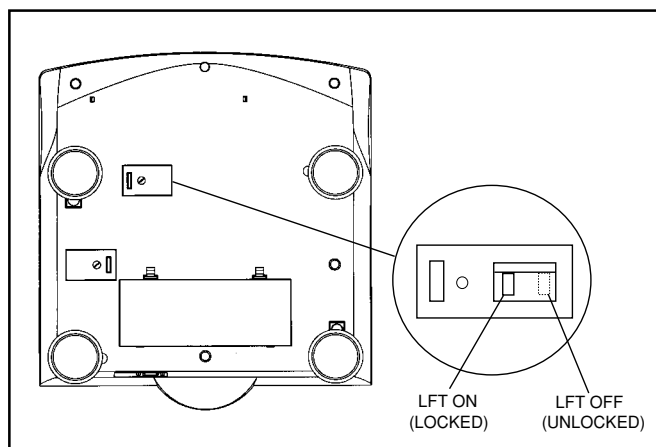

Bottom of Trooper

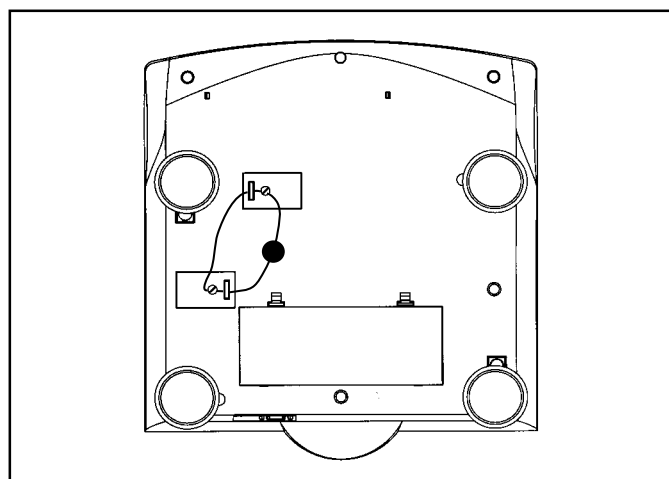

Sealing the Scale with a Lead Seal

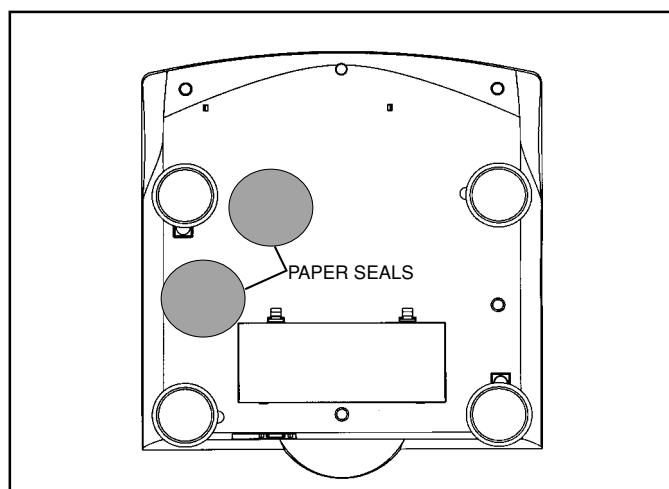

Sealing the Scale with a Paper Seal

#### Procedure

Set up Scale, and calibrate. After this is done, remove power from the Scale.

Turn the scale over in the position as shown and remove the Lock Switch cover plate.

Refer to the illustration at the left and notice the position of the LFT switch. To lock out the menus, slide the LFT switch to the position shown.

Replace the Lock Switch cover and housing screw cover. The two screws are cross drilled and can accept a wire seal.

**NOTICE:** The Trooper Scale has been tested and found to comply with Class III requirements of NIST Handbook 44.

After the Scale has been tested and found to comply with local applicable regulations by a local weights and measures official, it may be sealed as follows:

#### LEAD AND WIRE SEAL

See illustration at left. Place wire seal through the holes in the screw and ribs as shown and compress the lead seal in place.

#### PAPER SEAL

If an audit trail or paper seal will be used, place a paper seal over both access covers.

**6 CARE AND MAINTENANCE**

To keep the Scale operating properly, the housing should be kept clean and free from foreign material. If necessary, a cloth dampened with a mild detergent may be used.

**6.1 Troubleshooting**

<b>SYMPTOM</b>	<b>PROBABLE CAUSE(S)</b>	<b>REMEDY</b>
Unit will not turn on.	<p>Adapter not plugged in or properly connected.</p> <p>Batteries dead or not properly installed.</p> <p>Membrane switch failure.</p>	<p>Check power cord connections.</p> <p>Make sure adapter connector is plugged all the way into the Scale.</p> <p>Check battery connector.</p> <p>Check orientation of the batteries.</p> <p>Replace batteries.</p> <p>Check functions of membrane switch.</p>
Cannot zero Scale, or will not zero when turned on.	<p>Load on scale exceeds allowable zero % entered in ZERO parameter of Setup menu.</p> <p>Retain Zero Data is enabled in scale menu.</p>	<p>Remove load on scale to less than entered zero %.</p> <p>Change allowable zero % in ZERO parameter of Setup menu.</p> <p>Normal operation when this feature is disabled.</p>
Center of Zero display indicator erratic or does not appear with no load on scale platform.	Scale platform motion or disturbances exceed center of zero criteria.	<p>Remove disturbances or reduce motion.</p> <p>Increase AZT level in readout menu.</p> <p>Increase averaging level in read-out menu.</p>

## 6 CARE AND MAINTENANCE (Cont.)

### 6.1 Troubleshooting (Cont.)

SYMPTOM	PROBABLE CAUSE(S)	REMEDY
Cannot display weight in desired weighing unit.	Desired unit not set to ON in Readout menu.	Enable desired unit in Readout menu. See paragraph 4.4.4  Conversion too large (typically in g).
RS232 not working.	RS232 communication parameters set up incorrectly.  Improper or loose cable connections.	Verify communication parameters.  Check cable connections.
Unable to calibrate unit.	Software Lockout switch set to ON and Lock Switch on the circuit board set to open position.  Incorrect value for calibration mass.	Set LCL to OFF in the LocSW menu, and set Lock Switch on the circuit board to ON position. Refer to paragraph 4.4.6.  Use correct calibration mass.

### 6.2 Error Codes List

The following list describes the various error codes and which can appear on the display and the suggested remedy.

<b>LoBat</b>	Is indicated when batteries are weak. Approximately 20 minutes of operating time remain.
<b>Error 1</b>	Indicates an overload condition.
<b>Error 2</b>	Indicates an underload condition.
<b>Error 7</b>	EEPROM data incorrect.
<b>Error 14</b>	Zero exceeds <u>ZERO%</u> and cannot be zeroed.
<b>Err 21</b>	Calibration data does not match current full scale, Grad and Cal Point settings. Settings must be restored or the Scale must be recalibrated using the current settings.

### 6.3 Service Information

If the Troubleshooting section does not resolve or describe your problem, you will need to contact an authorized Ohaus Service Agent. For Service assistance in the United States, please call Aftermarket, Ohaus Corporation toll-free at (800) 526-0659. An Ohaus Product Service Specialist will be available to help you.

### 6.4 Accessories

<u>Description</u>	<u>Ohaus Part No.</u>
RS232 Interface Cable/Printer	80500432
RS232 Interface Cable/PC 25 Pin	80500431
RS232 Interface Cable/PC 9 Pin	80500433
Printer	AS142

### 6.5 Technical Data

#### Materials

ABS Housing  
Keypad/display overlay polyester

#### Ambient conditions

The technical data is valid under the following ambient conditions:

Ambient temperature        -10°C to 40C/ 14°F to 113°F  
Relative humidity            10%.....95%, noncondensing  
Height above sea level      up to 4000m  
Operability is assured at ambient temperatures between 5 and 40° C.

## 6.5 Technical Data (Cont.)

Standard Models	TR3RS	TR6RS	TR15RS	TR30RS
Default Capacity X Readability (lb)*	6lb X 0.001lb	15lb X 0.002lb	30lb X 0.005lb	60lb X 0.01lb
Default Capacity X Readability (kg)*	3kg X 0.0005kg	6kg X 0.001kg	15kg X 0.002kg	30kg X 0.005kg
Default Capacity X Readability (g)	3000g X 0.5g	6000g X 1g	15000g X 2g	30000g X 5g
NTEP Capacity X Readability (lb)	6lb X 0.002lb	15lb X 0.005lb	30lb X 0.01lb	60lb X 0.02lb
NTEP Capacity X Readability (kg)	3kg X 0.001kg	6kg X 0.002kg	15kg X 0.005kg	30kg X 0.01kg
NTEP Capacity X Readability (g)	3000g X 1g	6000g X 2g	15000g X 5g	30000g X 10g
Linearity (g)	± 0.5g	± 1.0g	± 2.0g	± 5.0g
<b>Item Number</b>	<b>TR3RS-2E0</b>	<b>TR6RS-2E0</b>	<b>TR15RS-2E0</b>	<b>TR30RS-2E0</b>

\* Default capacity and readability are dependant on calibration unit selected. The table above assumes that the calibration unit is the same as the displayed unit listed. The full list of capacities and readabilities in the different calibration units are listed below.

## General Specifications

Platform Size (w x d) (in/cm)	13.5 X 9" / 34 X 23
Scale Dimensions (w x d x h) (in/cm)	13.5 X 14.5 X 4.5 / 34.3 X 36.8 X 11.4
Shipping Dimensions (w x d x h) (in/cm)	17 X 17 X 8.5 / 42.2 X 42.2 X 21.6
Weight (lb/kg)	8.6 / 3.9
Resolution NTEP	1:3000
Resolution Maximum	6,000 - 7,500 depending on model
Stabilization time	1 - 4 seconds depending upon filter selection
Keyboard	4 function membrane switches
Weighing units	lb, kg, oz, g, oz
Display	Backlit LCD, 25.4mm, 1"
Power	AC Adapter or 6 alkaline C-type batteries
Typical Battery Life	Up to 100 hours
Span Calibration	1/3 to full capacity
Linearity Calibration (3-point calibration)	All models
Auto-zero tracking	Off, 0.5, 1, or 3 divisions
Construction	Stainless steel weighing pan, ABS plastic housing
Protection	IP43
Operating Temperature	14°F to 113°F / -10°C to 40°C
Storage Temperature	-40°F to 140°F / -20°C to 60°C

**NOTE:** All Trooper models meet the requirements of Approval Agencies: UL, FCC, CSA, CE. NTEP approval.

**Trooper Scale** \_\_\_\_\_

## **LIMITED WARRANTY**

Ohaus products are warranted against defects in materials and workmanship from the date of delivery through the duration of the warranty period. During the warranty period Ohaus will repair, or, at its option, replace any component (s) that proves to be defective at no charge, provided that the product is returned, freight prepaid, to Ohaus.

This warranty does not apply if the product has been damaged by accident or misuse, exposed to radioactive or corrosive materials, has foreign material penetrating to the inside of the product, or as a result of service or modification by other than Ohaus. In lieu of a properly returned warranty registration card, the warranty period shall begin on the date of shipment to the authorized dealer. No other express or implied warranty is given by Ohaus Corporation. Ohaus Corporation shall not be liable for any consequential damages.

As warranty legislation differs from state to state and country to country, please contact Ohaus or your local Ohaus dealer for further details.







Ohaus Corporation  
19A Chapin Road,  
P.O. Box 2033  
Pine Brook, NJ 07058-2033, USA  
Tel: (973) 377-9000  
Fax: (973) 593-0359  
[www.ohaus.com](http://www.ohaus.com)

Ohaus GmbH  
Ockerweg 3a  
D-35396 Giessen,  
GERMANY  
Tel: 9-011.....+49 641 71023

Ohaus  
Motores, 178  
08038 Barcelona,  
SPAIN  
Tel: 9-011.....+34 93 223 76 06

Ohaus Poland  
ul. Iwonicka 39  
PL 02-924 Warszawa,  
POLAND  
Tel: 9-011.....+4822 651 9232/8897

Ohaus Corporation Representation in CIS  
Sretensky Blv. 6/1, Office 6  
101000 Moscow, Russian Federation  
Tel: 9-011.....+7 095 921 4897

With offices worldwide.  
[www.ohaus.com](http://www.ohaus.com)

Ohaus UK Ltd  
64 Boston Road, Beaumont Leys  
Leicester LE4 1AW,  
ENGLAND  
Tel: 9-011.....+(44)116 234 5075

Ohaus s.a.r.l  
85, Rue Joseph-Bertrand, BP 30  
78221 Viroflay,  
FRANCE  
Tel: 9-011.....+33 (1) 39 24 01 93

Ohaus  
Italian Representative Office  
Via Vialba, 42  
20026 Novate Milanese (MI),  
ITALY  
Tel: 9-011.....+39 02 33332297

OHAUS Europe  
Heuwinkelstrasse  
CH-8606 Nanikon,  
SWITZERLAND  
Tel: 9-011.....+41-1-944 33 66

Ohaus MEC Region  
Hatarhalom u 4  
1173 Budapest,  
HUNGARY  
Tel: 9-011.....+36 1 253 07 04